

RECOMMENDED PCB LAYOUT  
DIMENSIONAL TOLERANCE: ±0.02

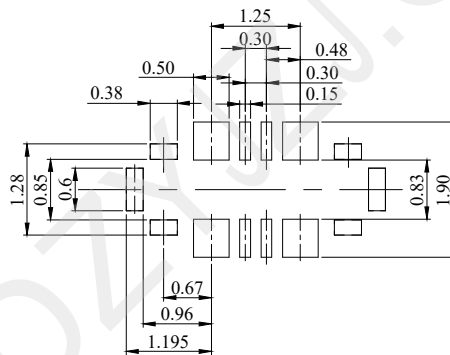

RECOMMENDED METAL DIMENSIONS (THICKNESS: 0.10 mm)  
DIMENSIONAL TOLERANCE: ±0.01

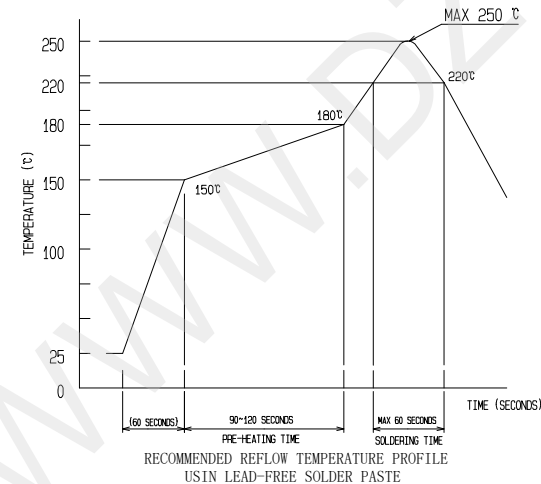

NOTE:

1: SPECIFICATION:

- 1.1 Voltage Rating: 60V AC/DC
- 1.2 Rated current : signal contact 0.3 AMPS/Pin  
power contact 12 AMPS /(All power Pin)
- 1.3 Temperature Range: -40 °C to +85°C
- 1.4 Contact Resistance:  
Signal pin: Initial: 50mΩ MAX  
AFTER TEST: Δ20mΩ  
Power pin: Initial: 15mΩ MAX  
AFTER TEST: 15mΩ MAX
- 1.5 Insulation Resistance  
Initial: 500 MΩ Minimum.  
After test: 500 MΩ Minimum.
- 1.6 Dielectric Withstanding Voltage  
NO EVIDENCE OF BREAKDOWN IN AC 100 V,  
1 MINUTE
- 1.7 MATING-UNMATING FORCE:  
MATING FORCE: 30N MAX  
UNMATING FORCE: 4N MIN
- 1.8 SALT WATER SPRAY: TEMPERATURE 35°C±2°C  
DENSITY OF SALT WATER 5±1%  
DURATION: 48±2 HOUR
- 1.9 Storage Temperature Range -40°C to +85°C  
0 to 90 % RH (Relative humidity).

4	POWER CONTACT-B	COPPER ALLOY, AuSn <sup>2</sup> Min ON CONTACT AREA, Au10 <sup>2</sup> Min ON SOLDER AREA, Ni 50u <sup>2</sup> Min ALL OVER			
3	POWER CONTACT-A	COPPER ALLOY, AuSn <sup>2</sup> Min ON CONTACT AREA, Au10 <sup>2</sup> Min ON SOLDER AREA, Ni 50u <sup>2</sup> Min ALL OVER	7	REEL	PLASTIC
2	SIGNAL CONTACT	COPPER ALLOY, AuSn <sup>2</sup> Min ON CONTACT AREA, Au10 <sup>2</sup> Min ON SOLDER AREA, Ni 50u <sup>2</sup> Min ALL OVER	6	COVER TAPE	PLYESTER
1	HOUSING	LCP, BLACK, UL 94 V-0	5	EMBOSSED CARRIER TAPE	PS
NO.	PART NAME	DESCRIPTION, REMARKS	NO.	PART NAME	DESCRIPTION, REMARKS



深圳市华宇创精密电子有限公司

<b>TOLERANCE:</b> X.X ±0.30 X.XX ±0.25 X.XXX ±0.15 X.' ±2' X.X' ±0.5'	DRAWN BY : 陈一鸣	DATE : 2014-02-23	PART NAME: 0.3PH 单槽BTB 公座4+6P
	CHECKED BY: 马跃	DATE : 2014-02-23	PART NO. HYC57M-BTB2X2-6-049
UNIT: mm [inch] SCALE: 1:1 SIZE: A4	APPROVED BY: 邱敏	DATE : 2014-02-23	DRAW NO: HYC-2511201537
			SHEET NO. 1 OF 1

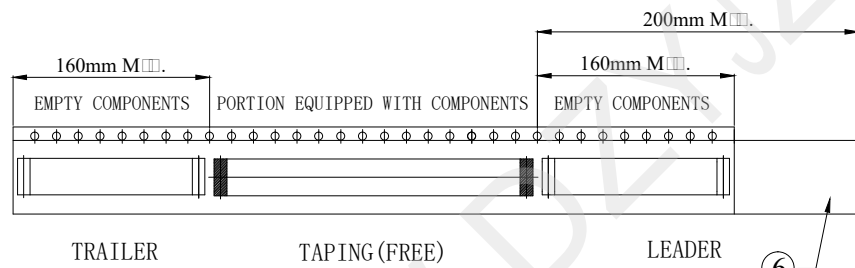
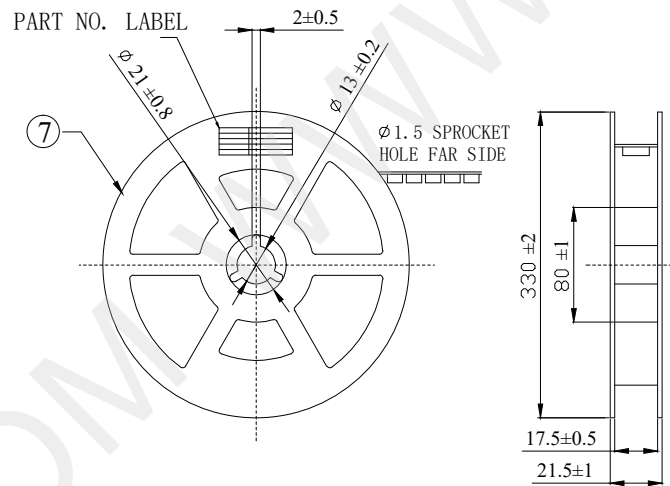
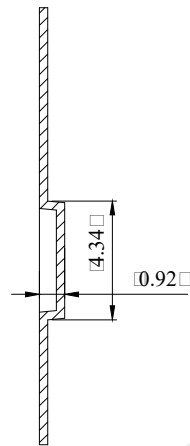
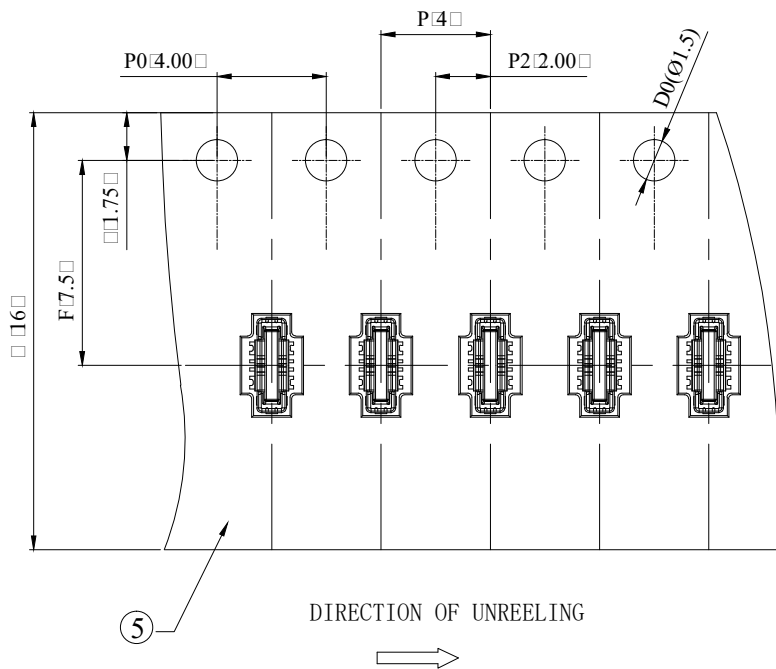

STYLE AND DIMENSION OF REEL

PER REEL 15000 CONNECTORS



深圳市华宇创精密电子有限公司

<b>TOLERANCE:</b> X.X ±0.30 X.XX ±0.25 X.XXX ±0.15 X' ±2' X.X' ±0.5'	<b>DRAWN BY :</b> 陈一鸣	<b>DATE :</b> 2014-02-23	<b>PART NAME:</b> 包装图		
	<b>CHECKED BY:</b> 马跃	<b>DATE :</b> 2014-02-23	<b>PART NO.</b>	_____	
<b>UNIT: mm [inch]</b> SCALE:1:1 SIZE: A4	<b>APPROVED BY:</b> 邱敏	<b>DATE :</b> 2014-02-23	<b>DRAW NO:</b>	_____	
			<b>SHEET NO.</b>	1 OF 1	

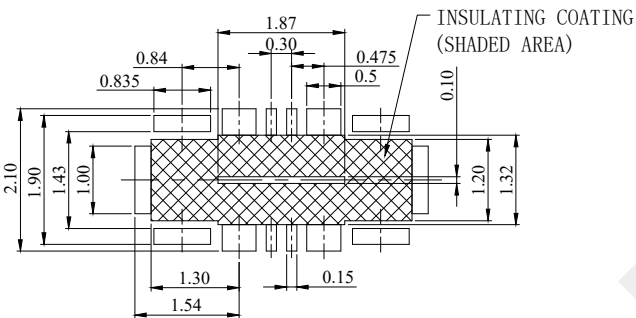
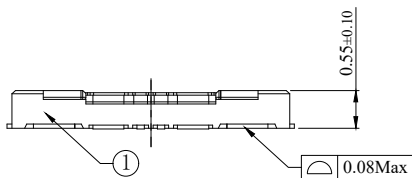
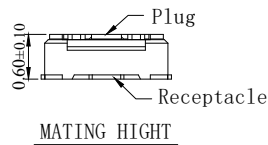
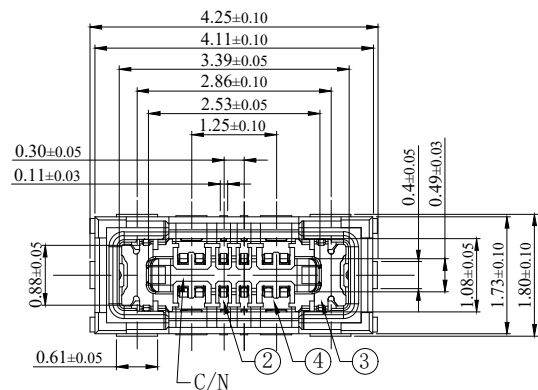

RECOMMENDED PCB LAYOUT  
DIMENSIONAL TOLERANCE: ±0.03

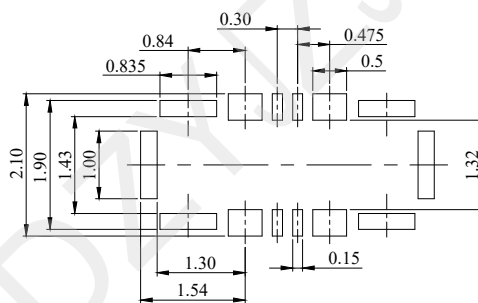

RECOMMENDED METAL DIMENSIONS (THICKNESS: 0.08 mm)  
DIMENSIONAL TOLERANCE: ±0.01

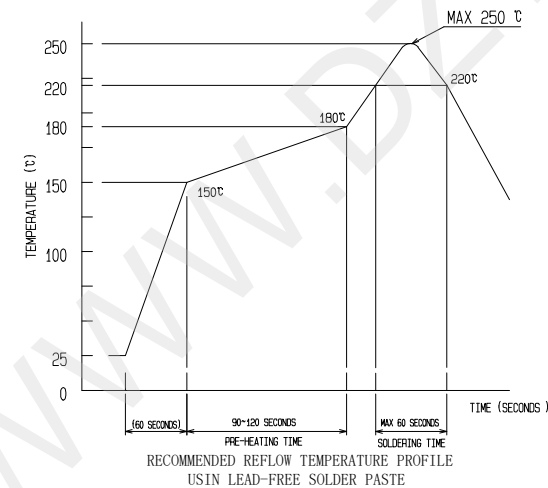

NOTE:

1:SPECIFICATION:

- 1.1 Voltage Rating: 60V AC/DC
- 1.2 Rated current : signal contact 0.3 AMPS/Pin  
power contact 12 AMPS Max/(All power Pin)
- 1.3 Temperature Range: -40 °C to +85°C
- 1.4 Contact Resistance:  
Signalpin:Initial:50mΩ MAX  
AFTER TEST:Δ20mΩ  
Power pin:Initial:15mΩ MAX  
AFTER TEST:15mΩ MAX
- 1.5 Insulation Resistance  
Initial: 500 MΩ Minimum.  
After test: 500 MΩ Minimum.
- 1.6 Dielectric Withstanding Voltage  
NO EVIDENCE OF BREAKDOWN IN AC 100 V,  
1 MINUTE
- 1.7 MATING-UNMATING FORCE:  
MATING FORCE: 30N MAX  
UNMATING FORCE: 4N MIN
- 1.8 SALT WATER SPRAY: TEMPERATURE 35°C±2°C  
DENSITY OF SALT WATER 5±1%  
DURATION:48±2 HOUR
- 1.9 Storage Temperature Range -40°C to +85°C  
0 to 90 % RH (Relative humidity).

4	POWER CONTACT-B	COPPER ALLOY,AuSn <sup>2</sup> Min ON CONTACT AREA,AuIn <sup>2</sup> Min ON SOLDER AREA,Ni 50u <sup>2</sup> Min ALL OVER		
3	POWER CONTACT-A	COPPER ALLOY,AuSn <sup>2</sup> Min ON CONTACT AREA,AuIn <sup>2</sup> Min ON SOLDER AREA,Ni 50u <sup>2</sup> Min ALL OVER	7	REEL PLASTIC
2	SIGNAL CONTACT	COPPER ALLOY,AuSn <sup>2</sup> Min ON CONTACT AREA,AuIn <sup>2</sup> Min ON SOLDER AREA,Ni 50u <sup>2</sup> Min ALL OVER	6	COVER TAPE PLYESTER
1	HOUSING	LCP , BLACK,UL 94 V-0	5	EMBOSSED CARRIER TAPE PS
NO.	PART NAME	DESCRIPTION , REMARKS	NO.	PART NAME DESCRIPTION , REMARKS



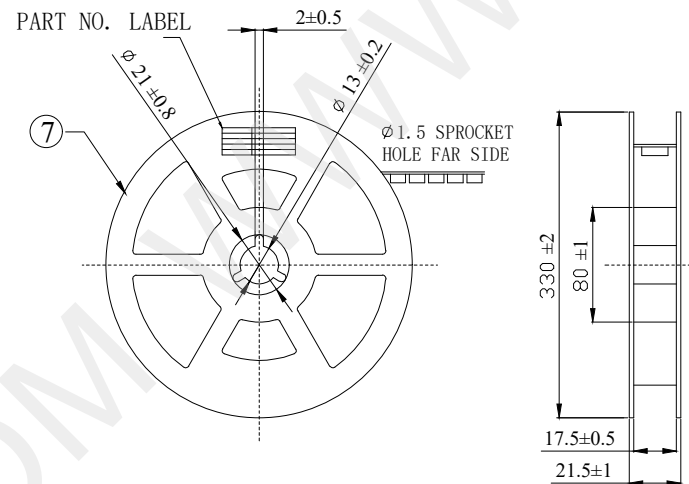
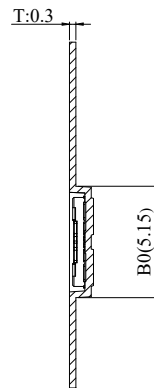
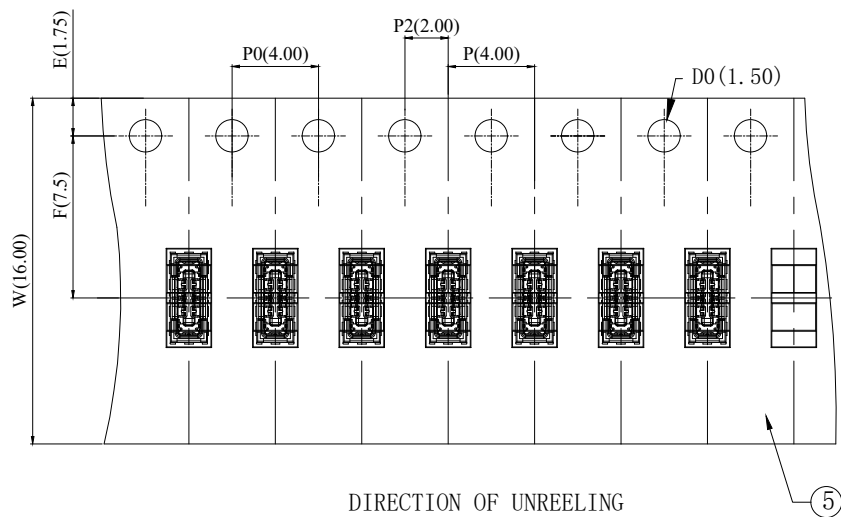

深圳市华宇创精密电子有限公司

<b>TOLERANCE:</b> X.X ±0.30 X.XX ±0.25 X.XXX ±0.15 X.' ±2' X.X' ±0.5'	DRAWN BY :	DATE :	PART NAME:
	陈一鸣	2014-02-23	0.3PH 单槽BTB 母座4+6P
UNIT: mm [inch] SCALE:1:1 SIZE: A4	CHECKED BY:	DATE :	PART NO.
	马跃	2014-02-23	HYC57M-BTB2X2-6-055
	APPROVED BY:	DATE :	DRAW NO:
	邱敏	2014-02-23	HYC-2511201539
			SHEET NO. 1 OF 1

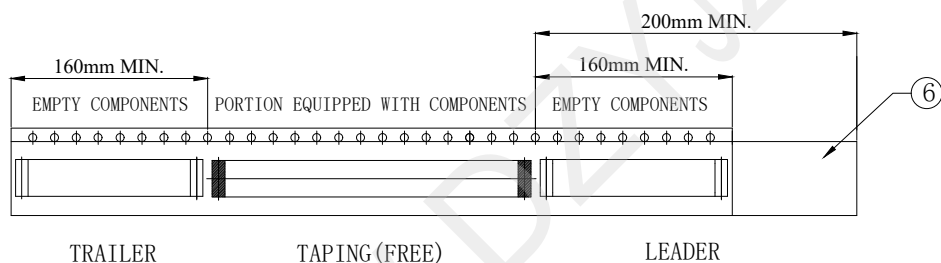

STYLE AND DIMENSION OF REEL  
PER REEL 15000 CONNECTORS

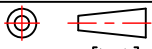

 <b>深圳市华宇创精密电子有限公司</b>			
<b>TOLERANCE:</b> X.X $\pm 0.30$ X.XX $\pm 0.25$ X.XXX $\pm 0.15$ X.' $\pm 2'$ X.X' $\pm 0.5'$	<b>DRAWN BY :</b> 陈一鸣	<b>DATE :</b> 2014-02-23	<b>PART NAME:</b> 包装图
	<b>CHECKED BY:</b> 马跃	<b>DATE :</b> 2014-02-23	<b>PART NO.</b> 
 <b>UNIT: mm [inch]</b> <b>SCALE: 1:1    SIZE: A4</b>	<b>APPROVED BY:</b> 邱敏	<b>DATE :</b> 2014-02-23	<b>MOLD NO.</b> 
			<b>DRAW NO:</b> 
			<b>SHEET NO.</b> 1 OF 1